

4

3

2

1

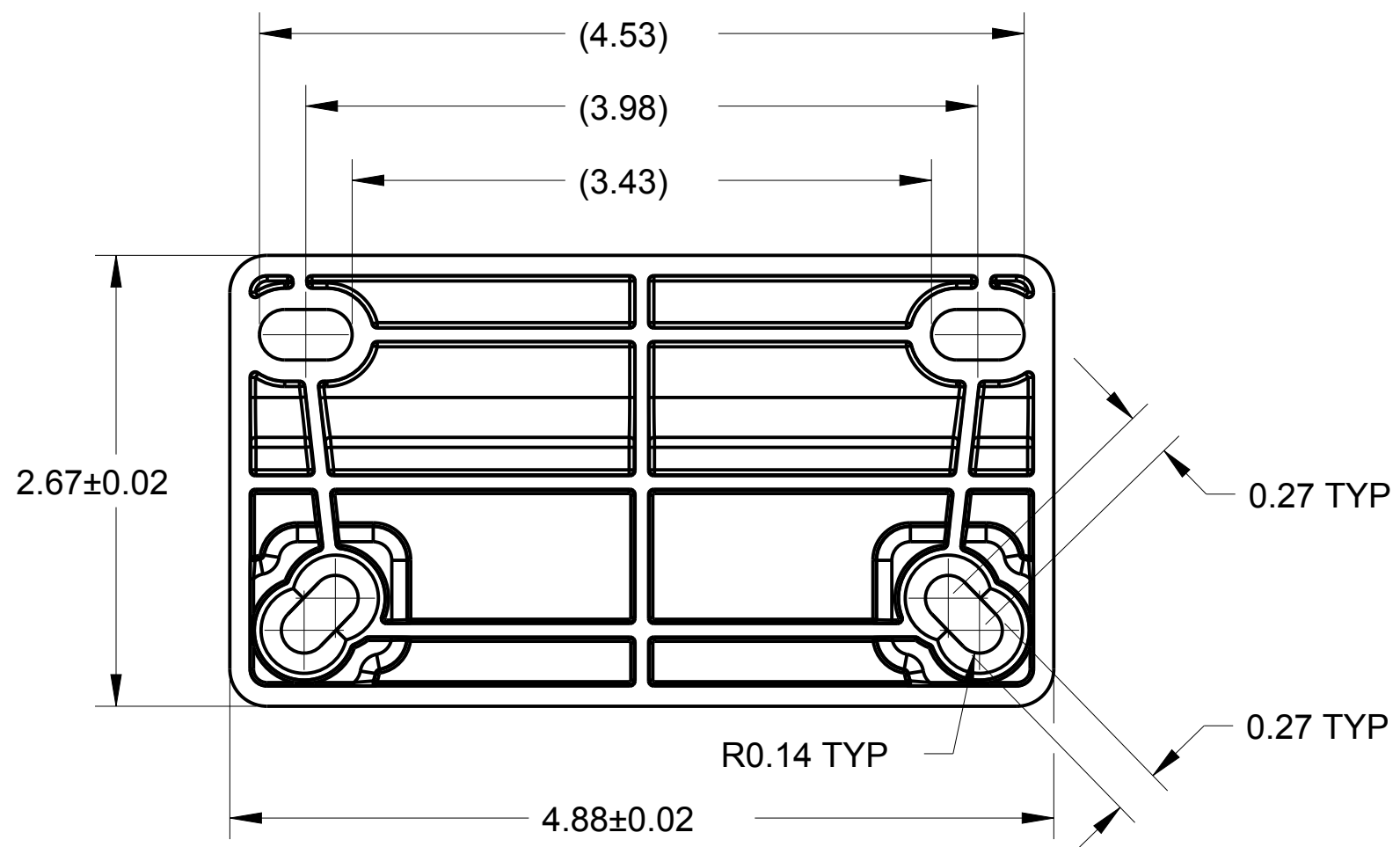
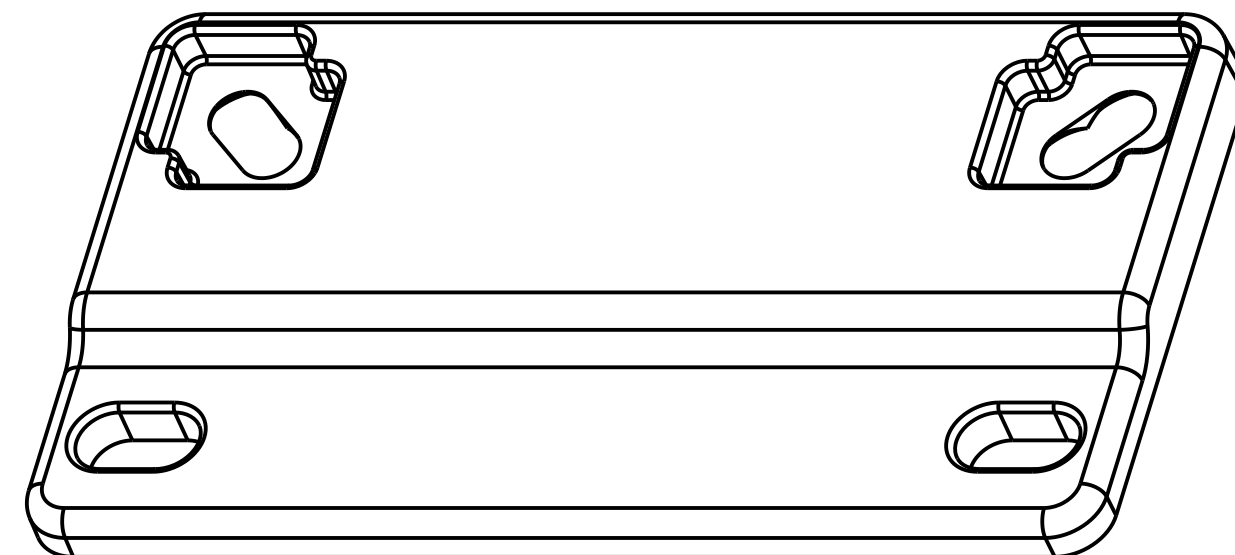
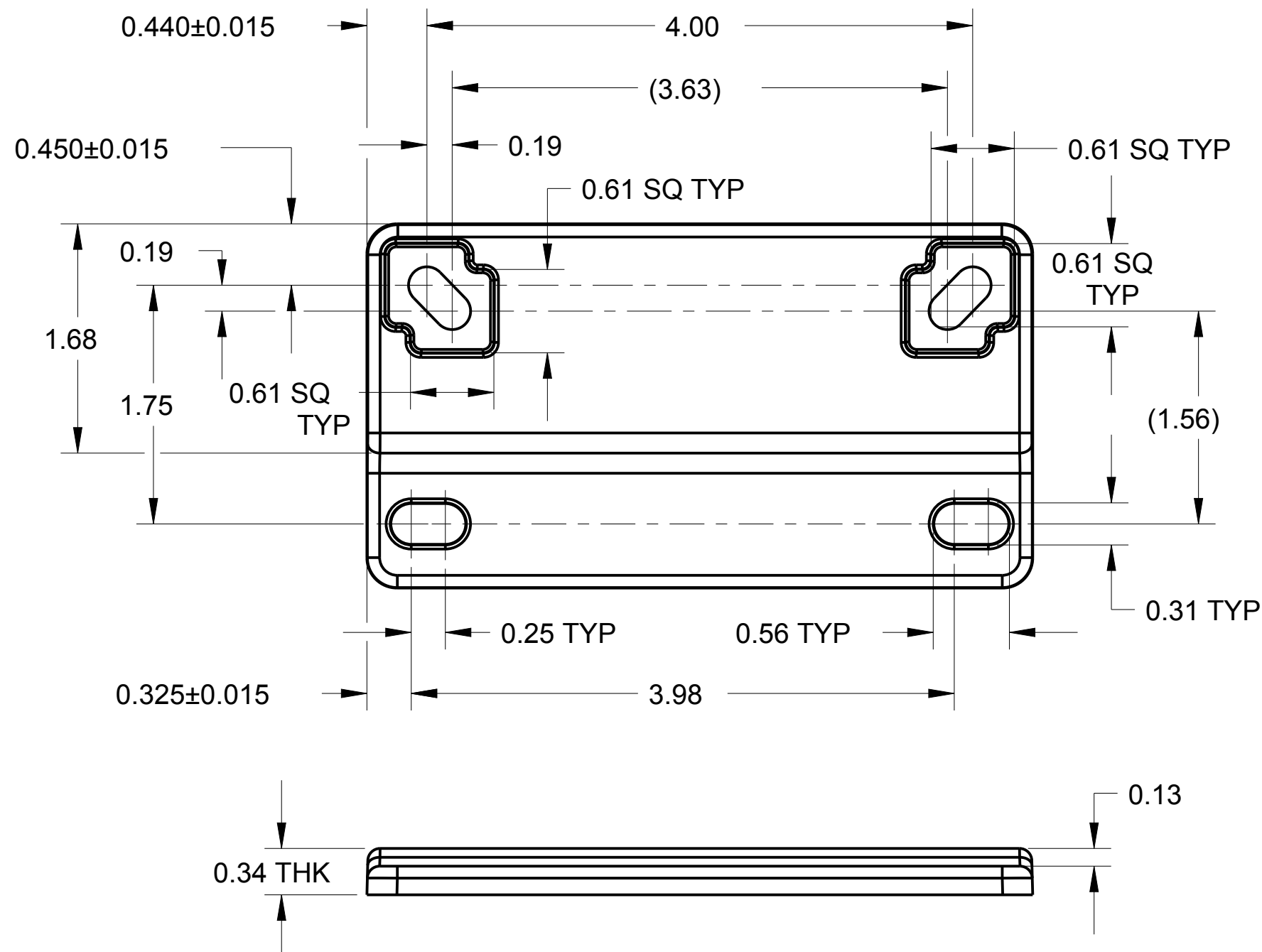

- NOTES:
1. MATERIAL: POLYCARBONATE, PC-FRO  
UL RECOGNIZED 94V-0, 94 5VA.
  2. COLOR: INTEGRA GREY, PANTONE 422C
  3. ALL FILLETS AND CORNER RADII TO BE .01 INCH UNLESS OTHERWISE SPECIFIED.
  4. GATE SHALL BE FLUSH TO .02 INCH RECESSED.
  5. MOLD FLASH NOT TO EXCEED .01 INCH.
  6. CONTAMINATION, BURNING AND DISCOLOR ARE NOT PERMITTED.
  7. PARTS MUST BE COMPLETELY FILLED. NO SHORTS.
  8. DRAG MARKS, PIN MARKS, SPLAY MARKS, FLOW LINES, PULLING VOIDS, CRACKS AND WARPING ARE NOT PERMITTED.

|     |  |                                 |    |      |         |             |  |   |  |  |   |   |
|-----|--|---------------------------------|----|------|---------|-------------|--|---|--|--|---|---|
| A   |  | RELEASED TO PRODUCTION AT REV A |    | W.T. | 1-6-14  |             |  | DEFAULT TOLERANCES<br>DECIMAL<br>.XX ±0.01<br>.XXX ±0.005<br>FRACTIONAL<br>± 1/64<br>ANGULAR<br>±1° |  |  | SCALE<br>1.000<br>SHEET<br>1 of 1<br>TITLE<br>6 INCH MOUNTING FLANGE<br>DATE<br>01.06.14<br>DRAWING NUMBER<br>MFLK6 | MUM INDUSTRIES<br>7750 TYLER BLVD MENTOR, OHIO (440) 289-8155 FAX (440) 289-8188<br>DRAWN BY<br>W.TIDWELL<br>REV<br>A |
| REV |  | DESCRIPTION                     | BY | DATE | ECN NO. | APPROVED BY |  |   |  |  |   |   |

4

3

2

1