

4

3

2

1

D

D

C

C

B

B

A

A

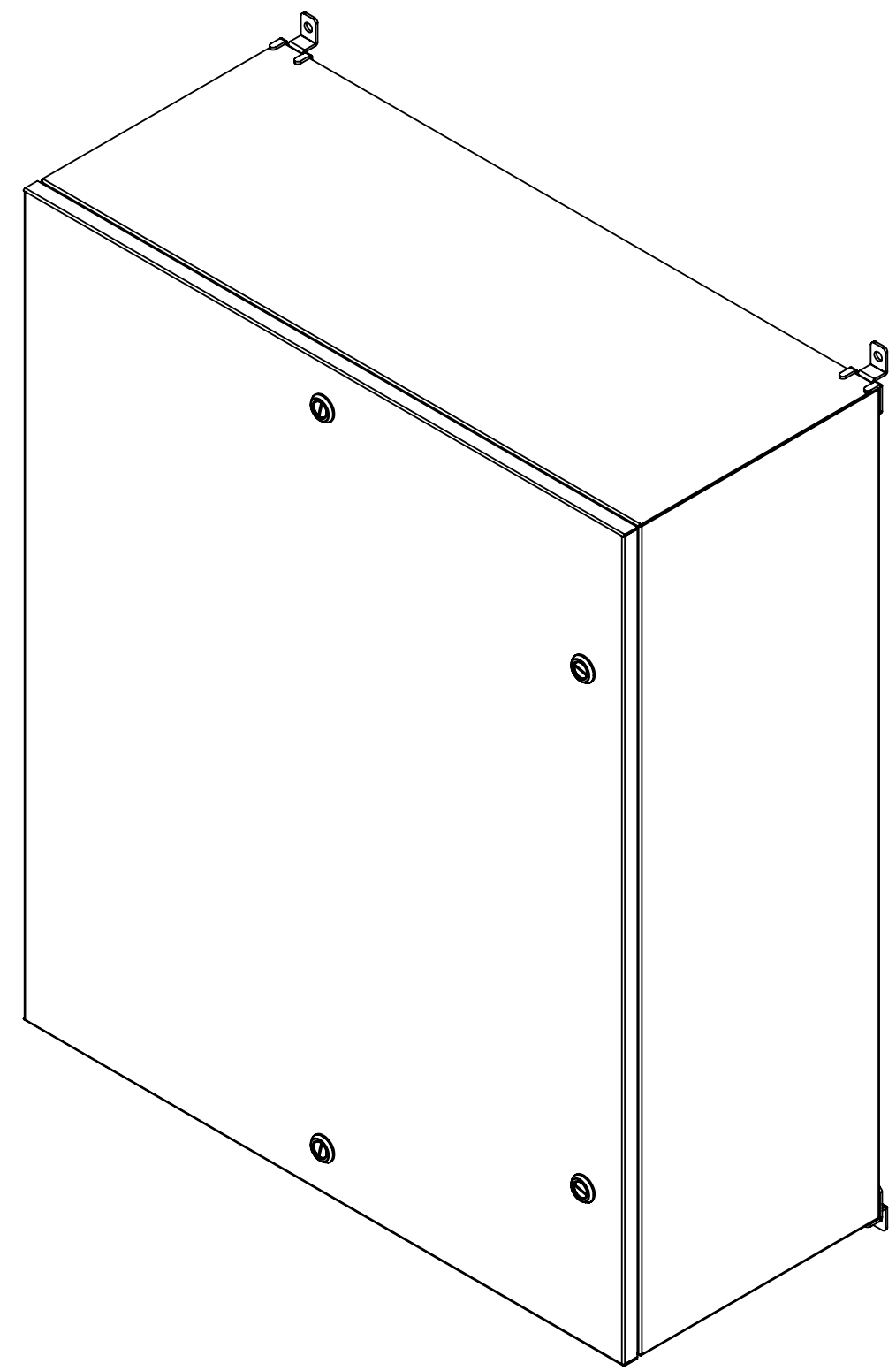
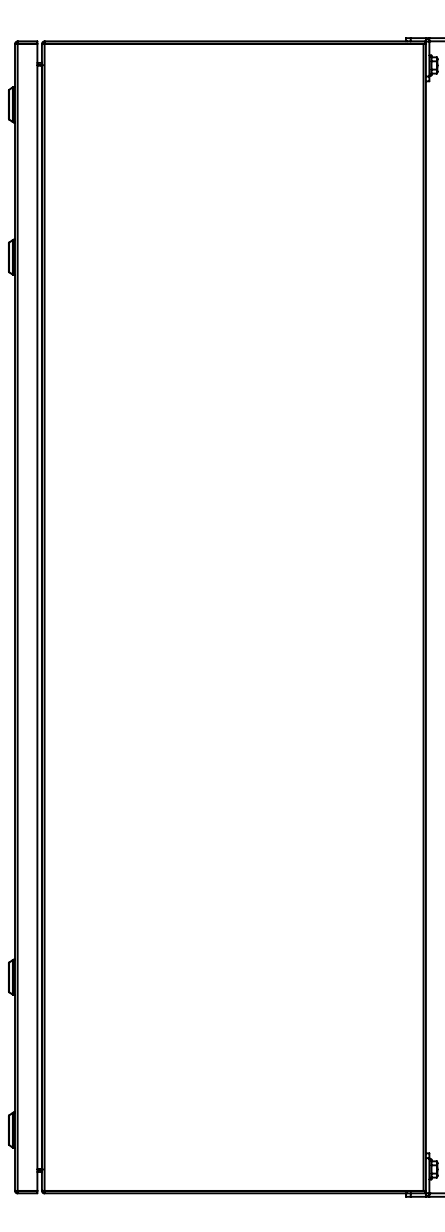
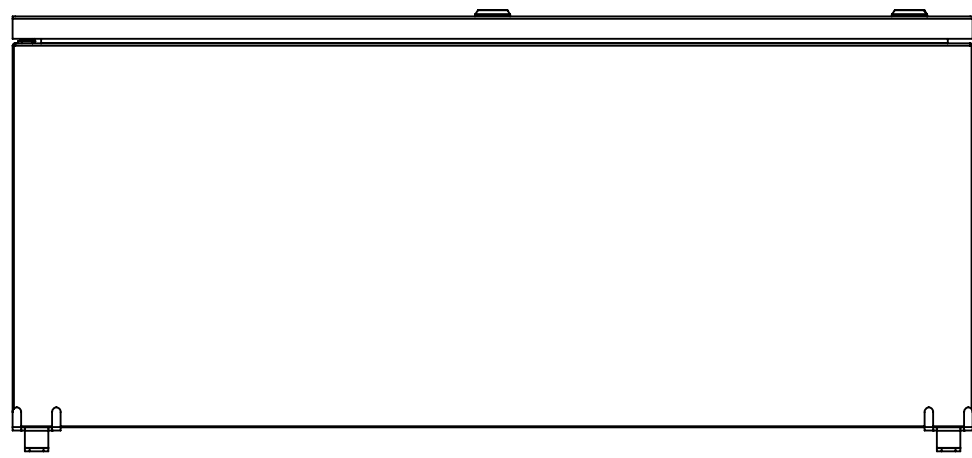
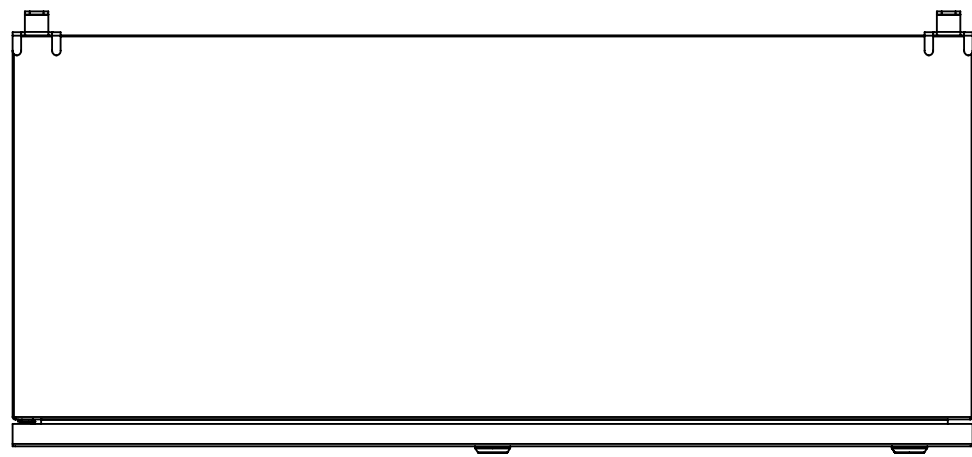
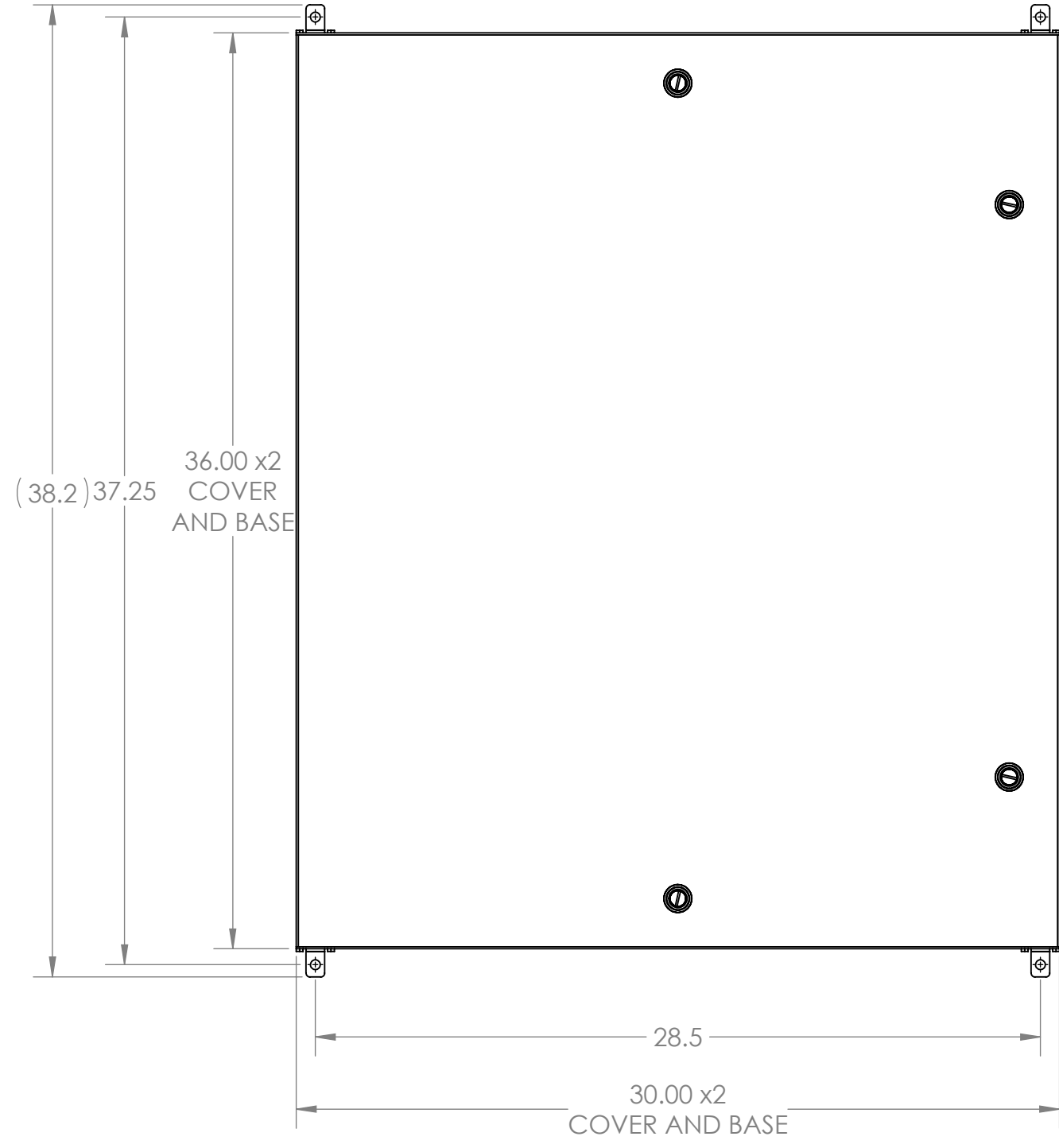
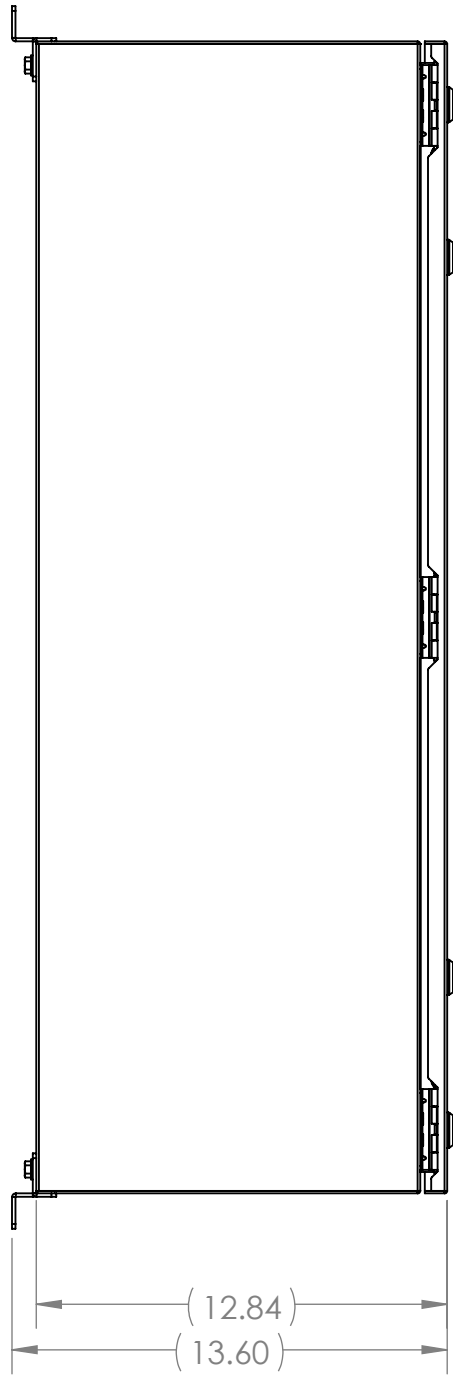

- NOTES:
 1. BASE MATERIAL: 14 Ga. (.075") 304 SS
 2. COVER MATERIAL: 14 Ga. (.075") 304 SS

UNLESS OTHERWISE SPECIFIED: DIMENSIONS ARE IN INCHES (MM) AND ARE NOMINAL ONLY		INTEGRA ENCLOSURES <small>A DIVISION OF MUM INDUSTRIES 8989 TYLER BLVD. MENTOR, OH ENCLOSURES (440)269-8155 FAX (440)269-8166</small>	
<small>PROPRIETARY AND CONFIDENTIAL THE INFORMATION CONTAINED IN THIS DRAWING IS THE SOLE PROPERTY OF MUM INDUSTRIES INC. ANY REPRODUCTION IN PART OR AS A WHOLE WITHOUT THE WRITTEN PERMISSION OF MUM INDUSTRIES INC. IS PROHIBITED.</small>		DWG. NO. W363012-4PQ-BT	
SIZE C	DESCRIPTION: WALL-36X30X12-304- PHN-QTL	REV C	SCALE: 1:6 WEIGHT: SHEET 1 OF 2
DRAWN BY: JMS 05.26.2021			

4

3

2

1

4

3

2

1

D

D

C

C

B

B

A

A

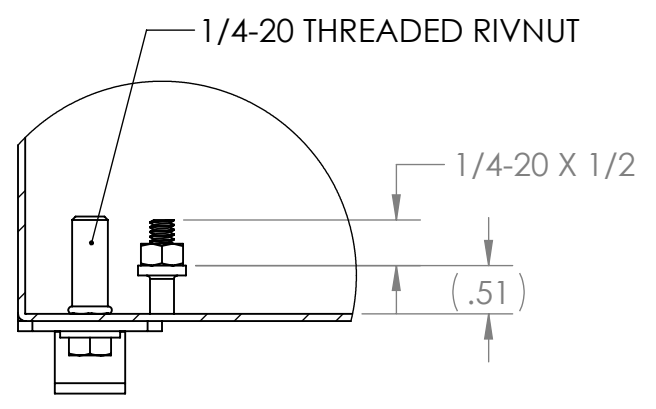
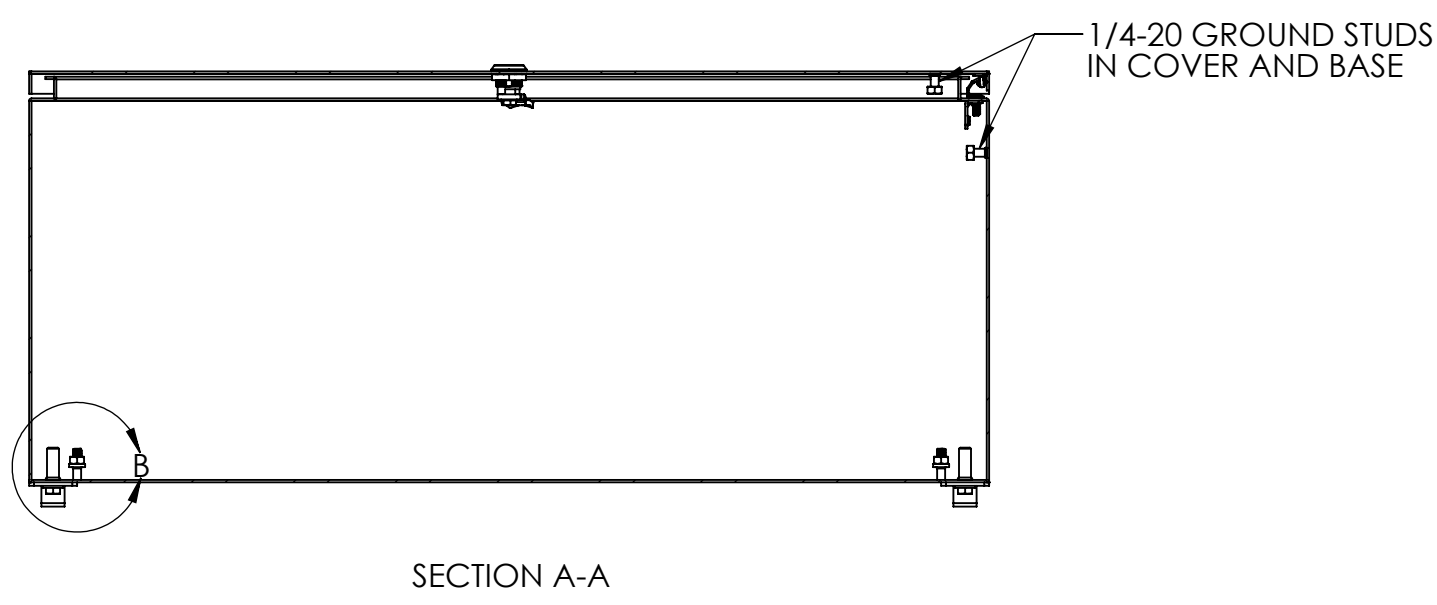
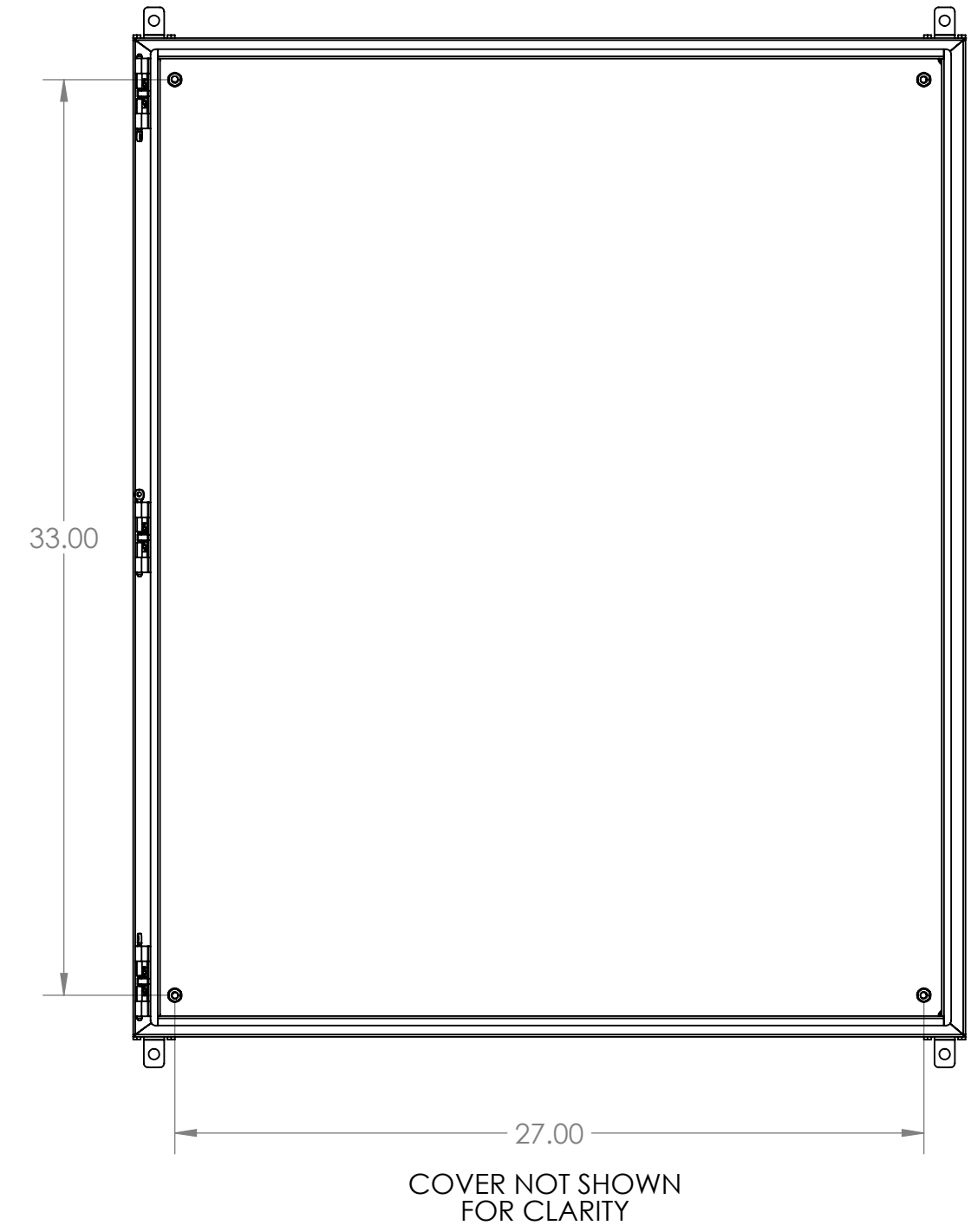
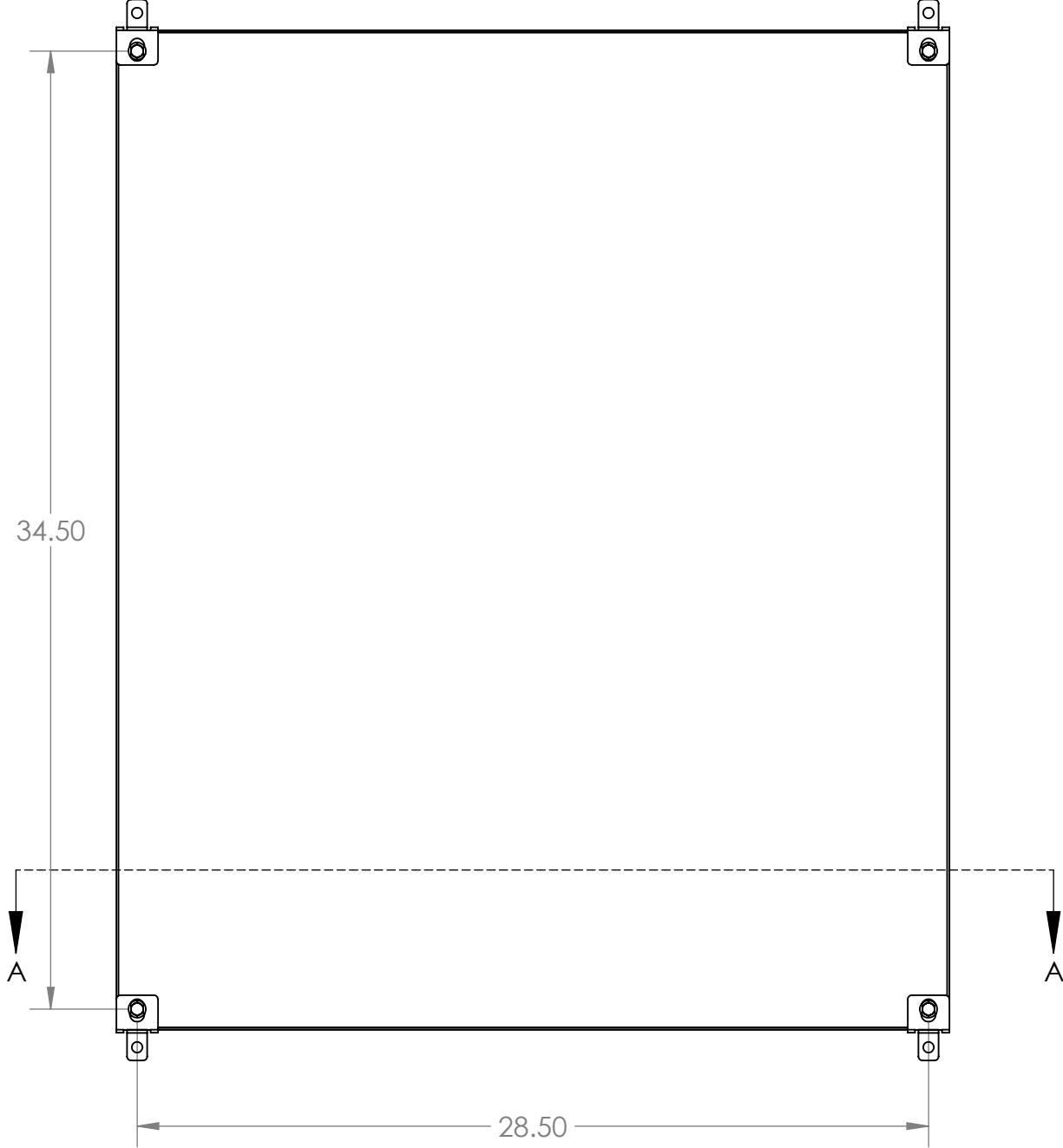

DETAIL B x 4
SCALE 1 : 2

UNLESS OTHERWISE SPECIFIED: DIMENSIONS ARE IN INCHES (MM) AND ARE NOMINAL ONLY		INTEGRA ENCLOSURES  A DIVISION OF MUM INDUSTRIES 8989 TYLER BLVD. MENTOR, OH ENCLOSURES (440)269-8155 FAX (440)269-8166	
PROPRIETARY AND CONFIDENTIAL THE INFORMATION CONTAINED IN THIS DRAWING IS THE SOLE PROPERTY OF MUM INDUSTRIES INC. ANY REPRODUCTION IN PART OR AS A WHOLE WITHOUT THE WRITTEN PERMISSION OF MUM INDUSTRIES INC. IS PROHIBITED.		DWG. NO. W363012-4PQ-BT	
SIZE C	DESCRIPTION: WALL-36X30X12-304- PHN-QTL	REV C	SCALE: 1:6 WEIGHT: SHEET 2 OF 2
DRAWN BY: JMS 05.26.2021			

4

3

2

1