

4

3

2

1

B

B

A

A

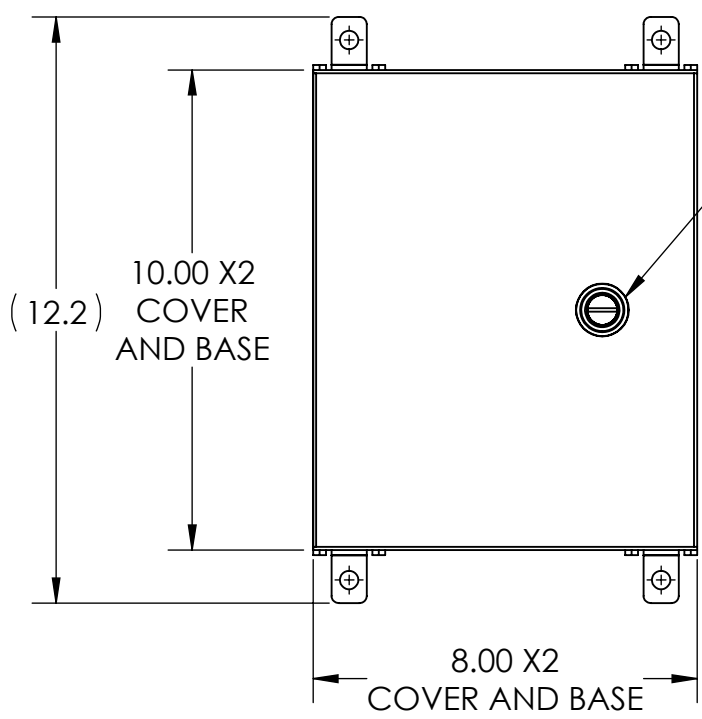
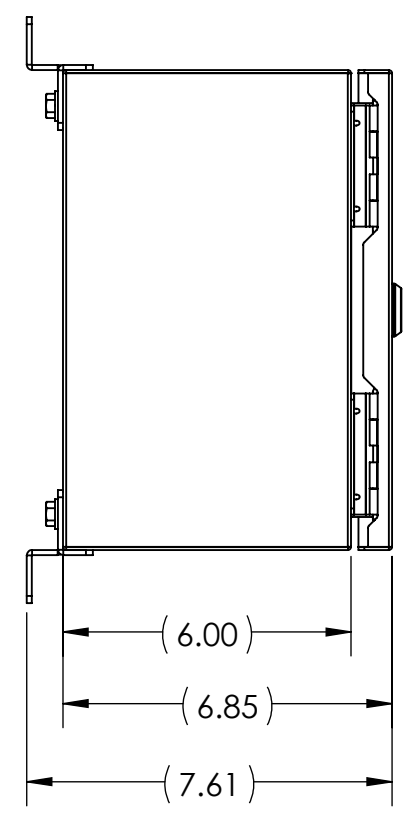

SLOTTED QUARTER TURN LATCH

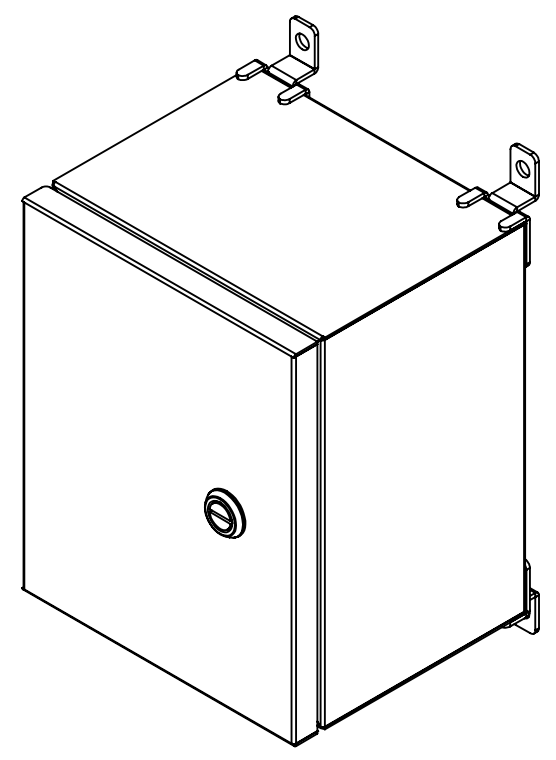
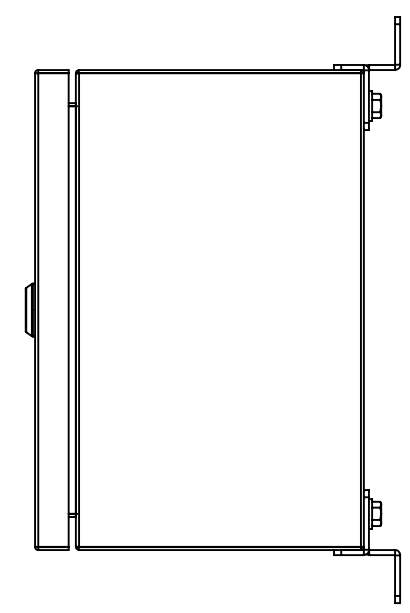
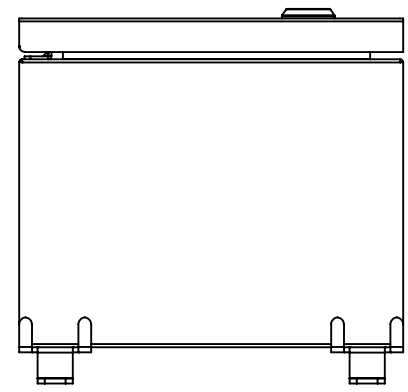
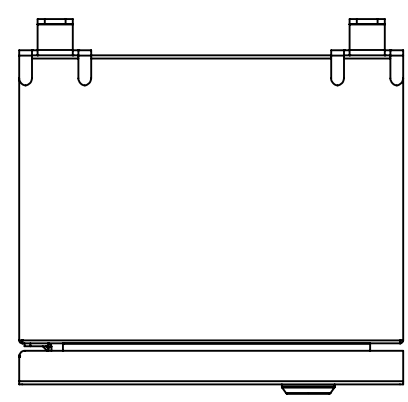

- NOTE:
 1. BASE MATERIAL: 16 Ga. (.060") 304 SS
 2. COVER MATERIAL: 16 Ga. (.060") 304 SS

INTEGRA ENCLOSURES
 A DIVISION OF MUM INDUSTRIES
 8989 TYLER BLVD. MENTOR, OH
 (440)269-8155 FAX (440)269-8166

UNLESS OTHERWISE SPECIFIED: DIMENSIONS ARE IN INCHES [MM] AND ARE NOMINAL ONLY			DWG. NO. W100806-4PQ-BT	
PROPRIETARY AND CONFIDENTIAL THE INFORMATION CONTAINED IN THIS DRAWING IS THE SOLE PROPERTY OF MUM INDUSTRIES INC. ANY REPRODUCTION IN PART OR AS A WHOLE WITHOUT THE WRITTEN PERMISSION OF MUM INDUSTRIES INC. IS PROHIBITED.				
SIZE B	DESCRIPTION: WALL-10X08X06-304-PHN-QTL	REV H		
DRAWN BY: TP	12.09.2024	SCALE: 1:4	WEIGHT:	SHEET 1 OF 2

4

3

2

1

4

3

2

1

B

B

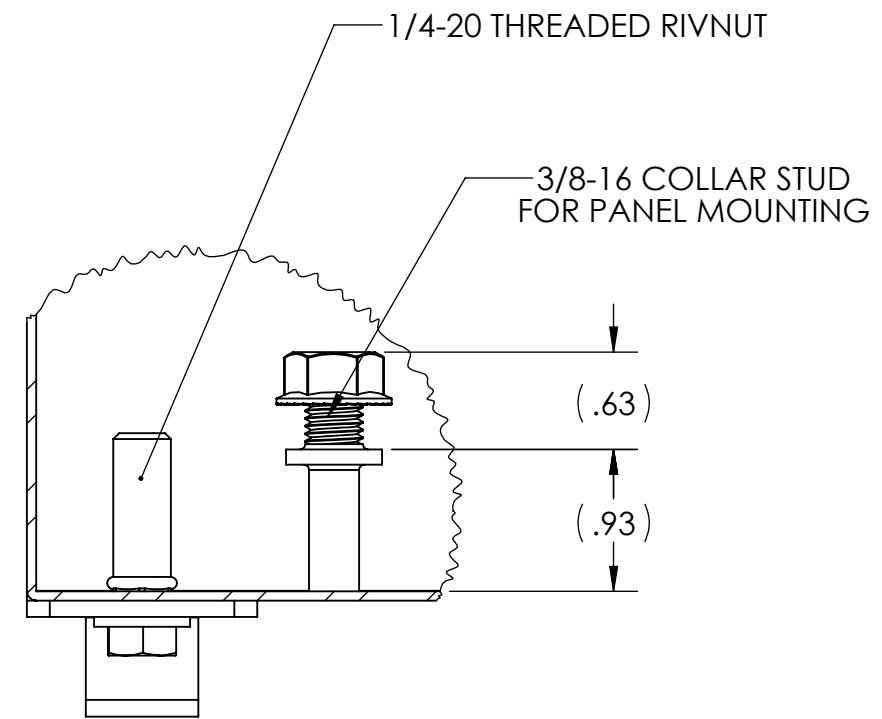
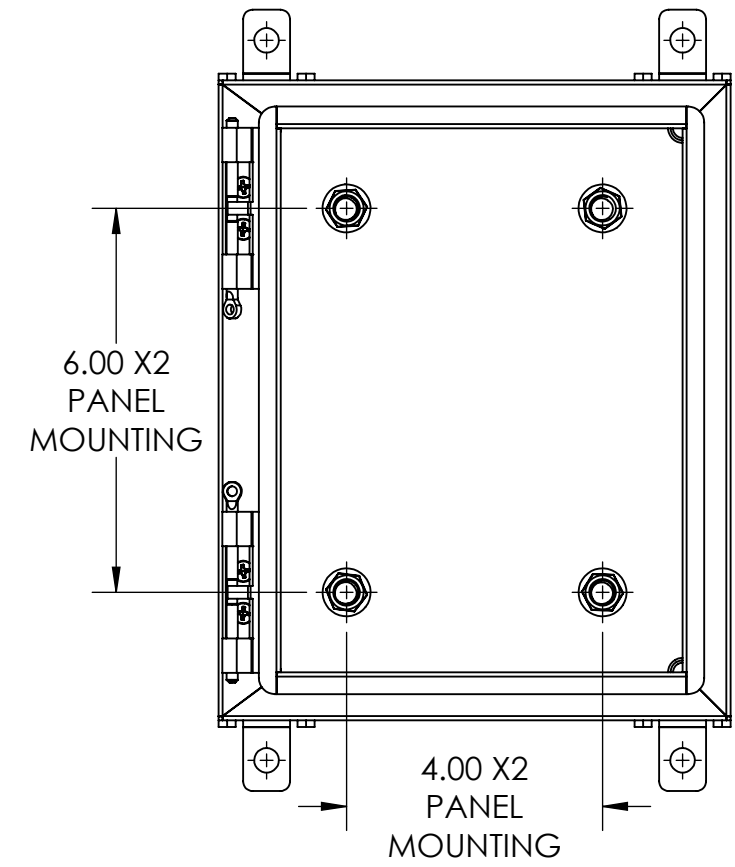
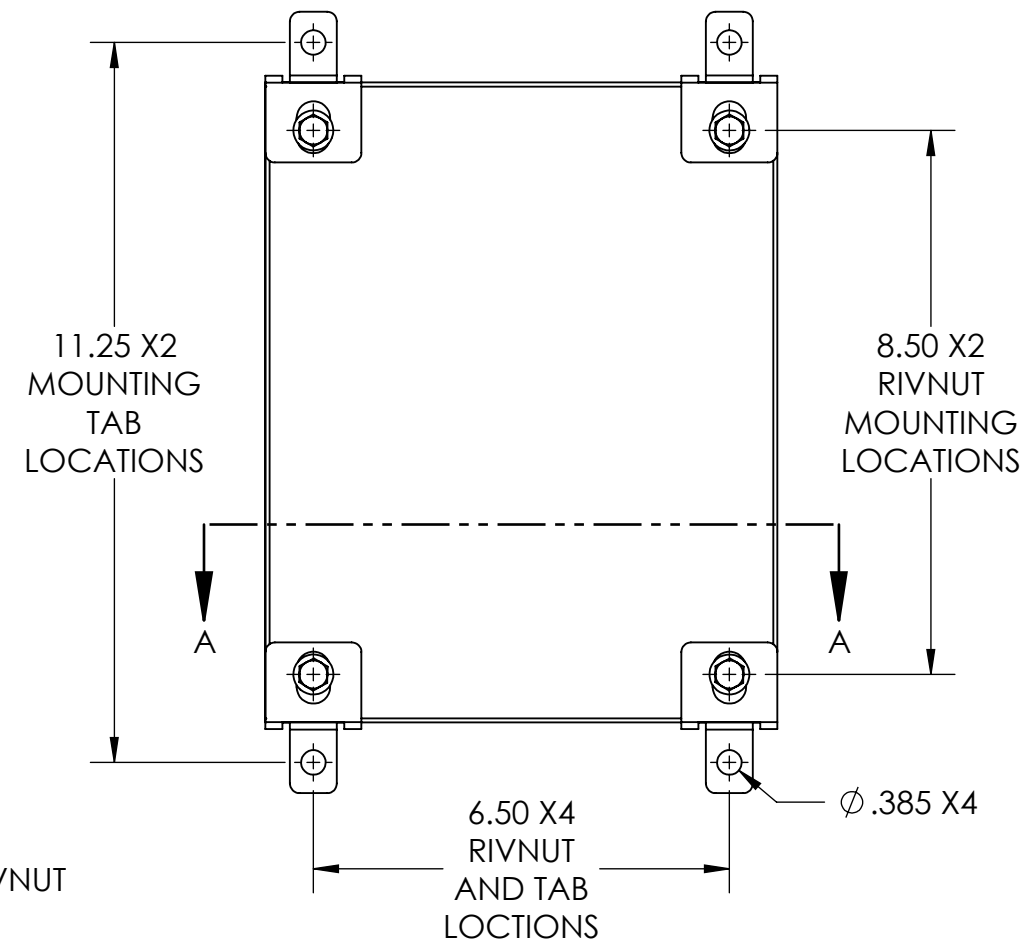

DETAIL B
SCALE 4 : 5

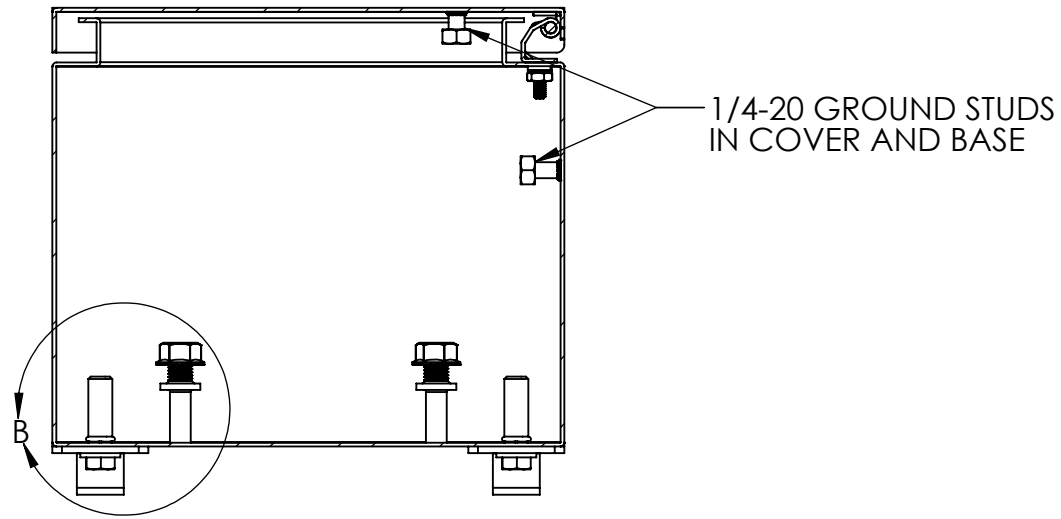

SECTION A-A

INTEGRA ENCLOSURES

INTEGRA ENCLOSURES A DIVISION OF MUM INDUSTRIES
8989 TYLER BLVD. MENTOR, OH
(440)269-8155 FAX (440)269-8166

UNLESS OTHERWISE SPECIFIED:
DIMENSIONS ARE IN INCHES [MM]
AND ARE NOMINAL ONLY

PROPRIETARY AND CONFIDENTIAL
THE INFORMATION CONTAINED IN THIS
DRAWING IS THE SOLE PROPERTY OF
MUM INDUSTRIES INC. ANY
REPRODUCTION IN PART OR AS A WHOLE
WITHOUT THE WRITTEN PERMISSION OF
MUM INDUSTRIES INC. IS PROHIBITED.

DRAWN BY: TP 12.09.2024

DWG. NO.
W100806-4PQ-BT

SIZE	DESCRIPTION:	REV
B	WALL-10X08X06-304-PHN-QTL	H

SCALE: 1:3 WEIGHT: SHEET 2 OF 2

4

3

2

1

A

A