

4

3

2

1

B

B

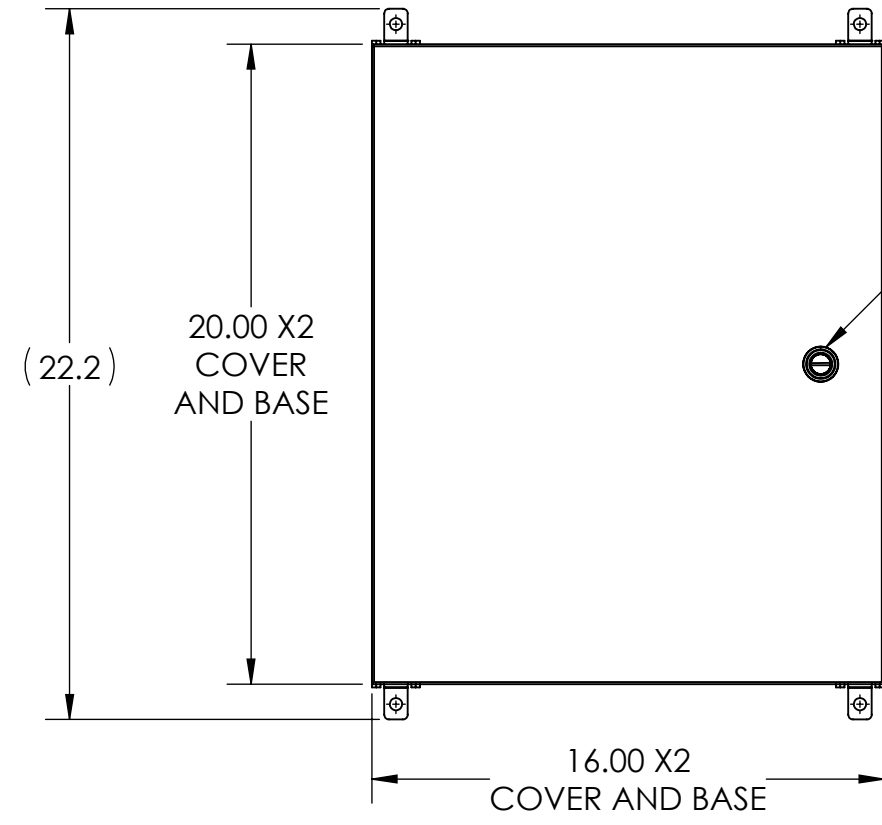
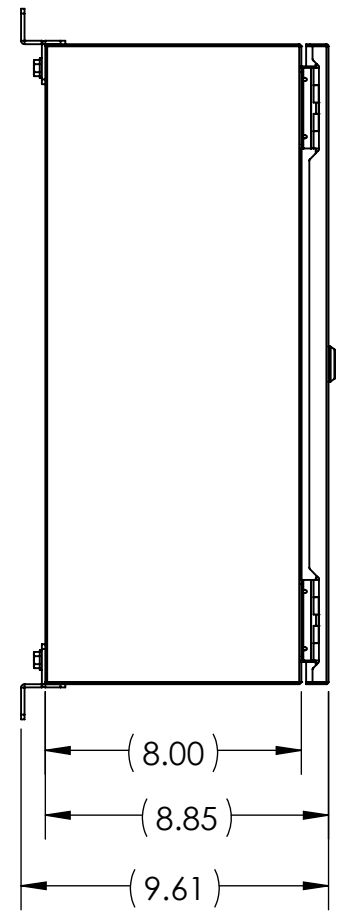

SLOTTED QUARTER TURN LATCH

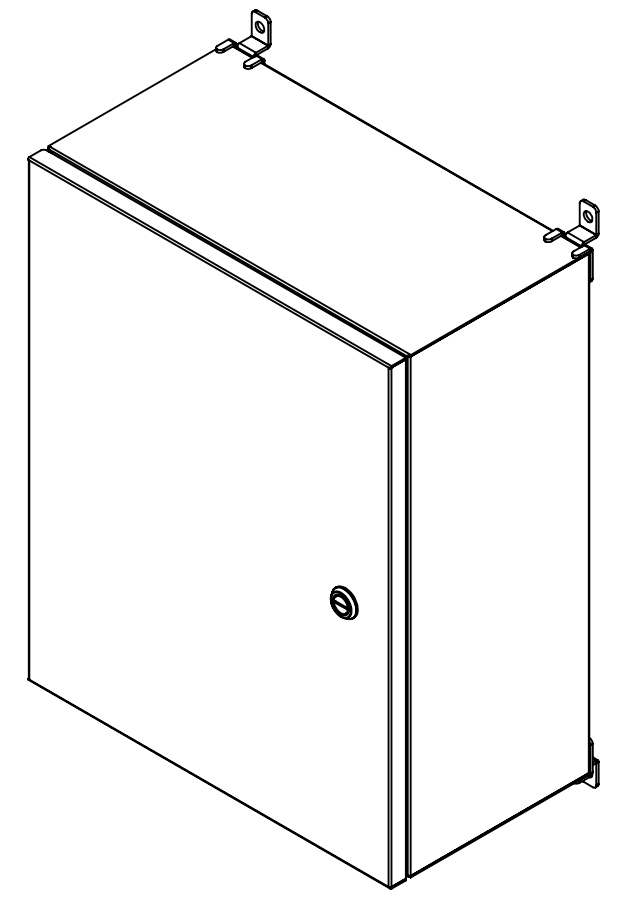
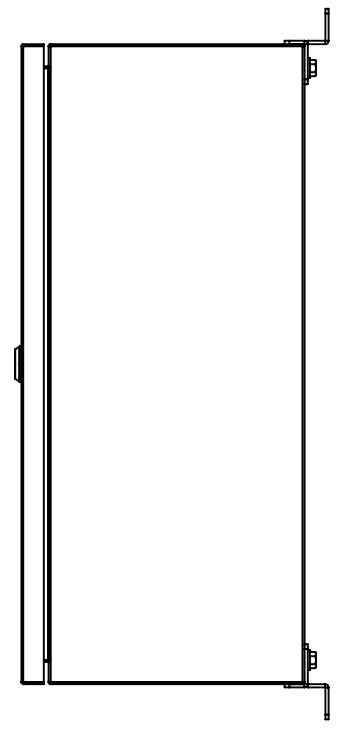

A

A

- NOTE:
 1. BASE MATERIAL: 16 Ga. (.060") 304 SS
 2. COVER MATERIAL: 16 Ga. (.060") 304 SS

INTEGRA ENCLOSURES
 A DIVISION OF MUM INDUSTRIES
 8989 TYLER BLVD. MENTOR, OH
 (440)269-8155 FAX (440)269-8166

UNLESS OTHERWISE SPECIFIED:
 DIMENSIONS ARE IN INCHES [MM]
 AND ARE NOMINAL ONLY

PROPRIETARY AND CONFIDENTIAL
 THE INFORMATION CONTAINED IN THIS
 DRAWING IS THE SOLE PROPERTY OF
 MUM INDUSTRIES INC. ANY
 REPRODUCTION IN PART OR AS A WHOLE
 WITHOUT THE WRITTEN PERMISSION OF
 MUM INDUSTRIES INC. IS PROHIBITED.

DWG. NO.		
WEB-W201608-4PQ-BT		
SIZE	DESCRIPTION:	REV
B	WALL-20X16X08-304- PHN-QTL	G
DRAWN BY:	CV	05.05.2021
SCALE: 1:6	WEIGHT:	SHEET 1 OF 2

4

3

2

1

4

3

2

1

B

B

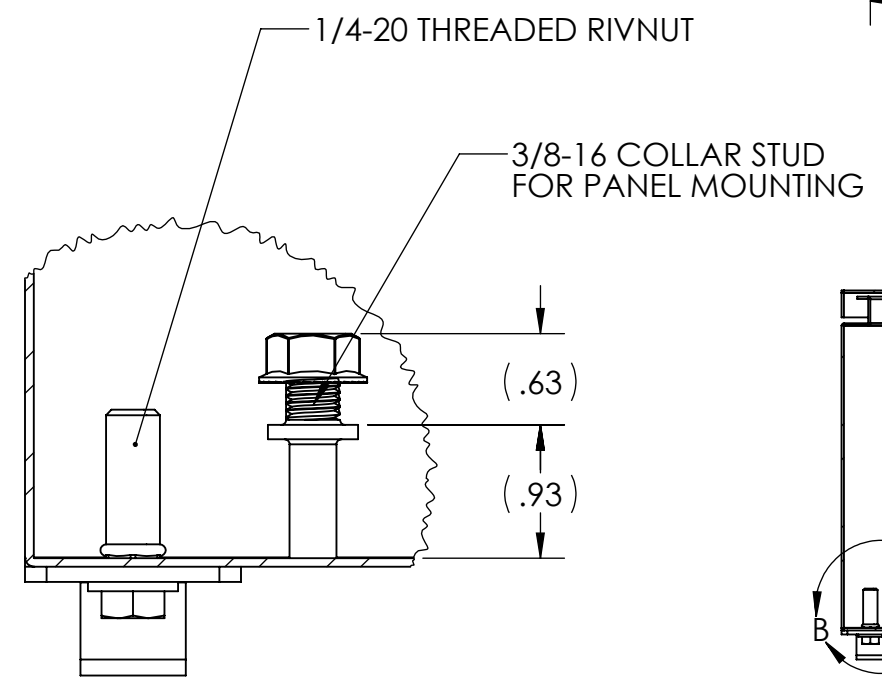
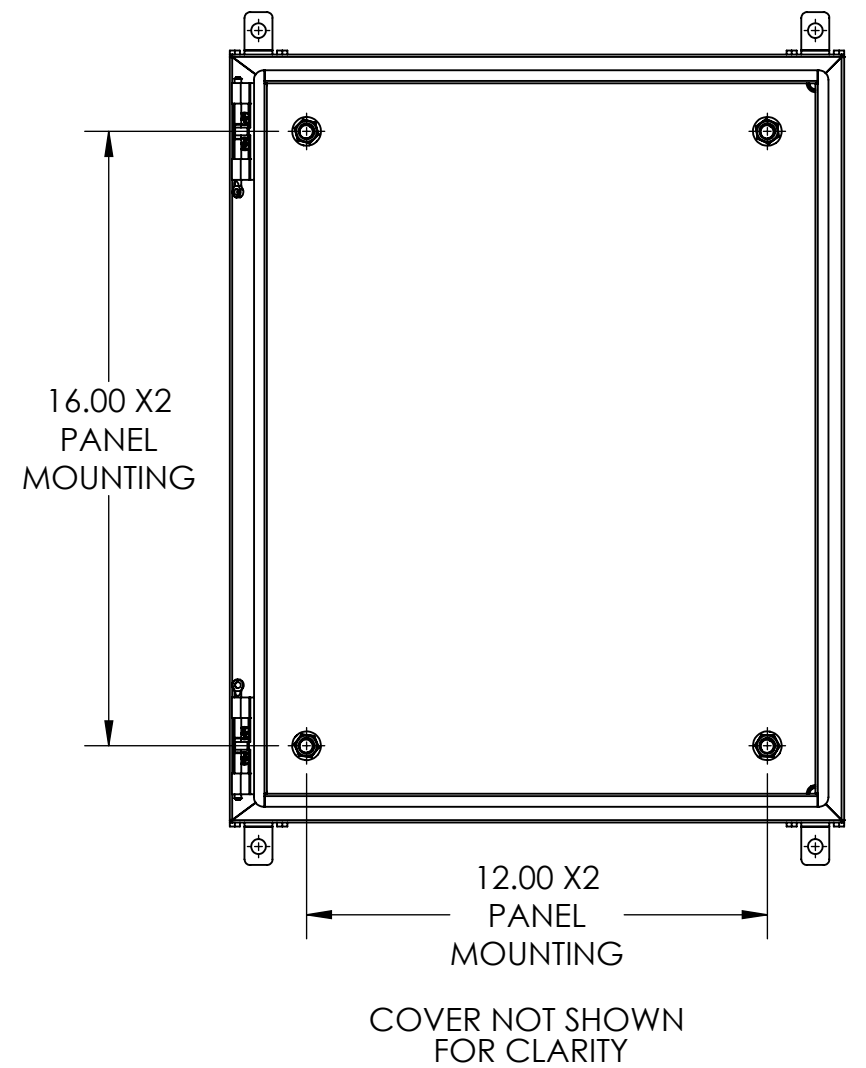
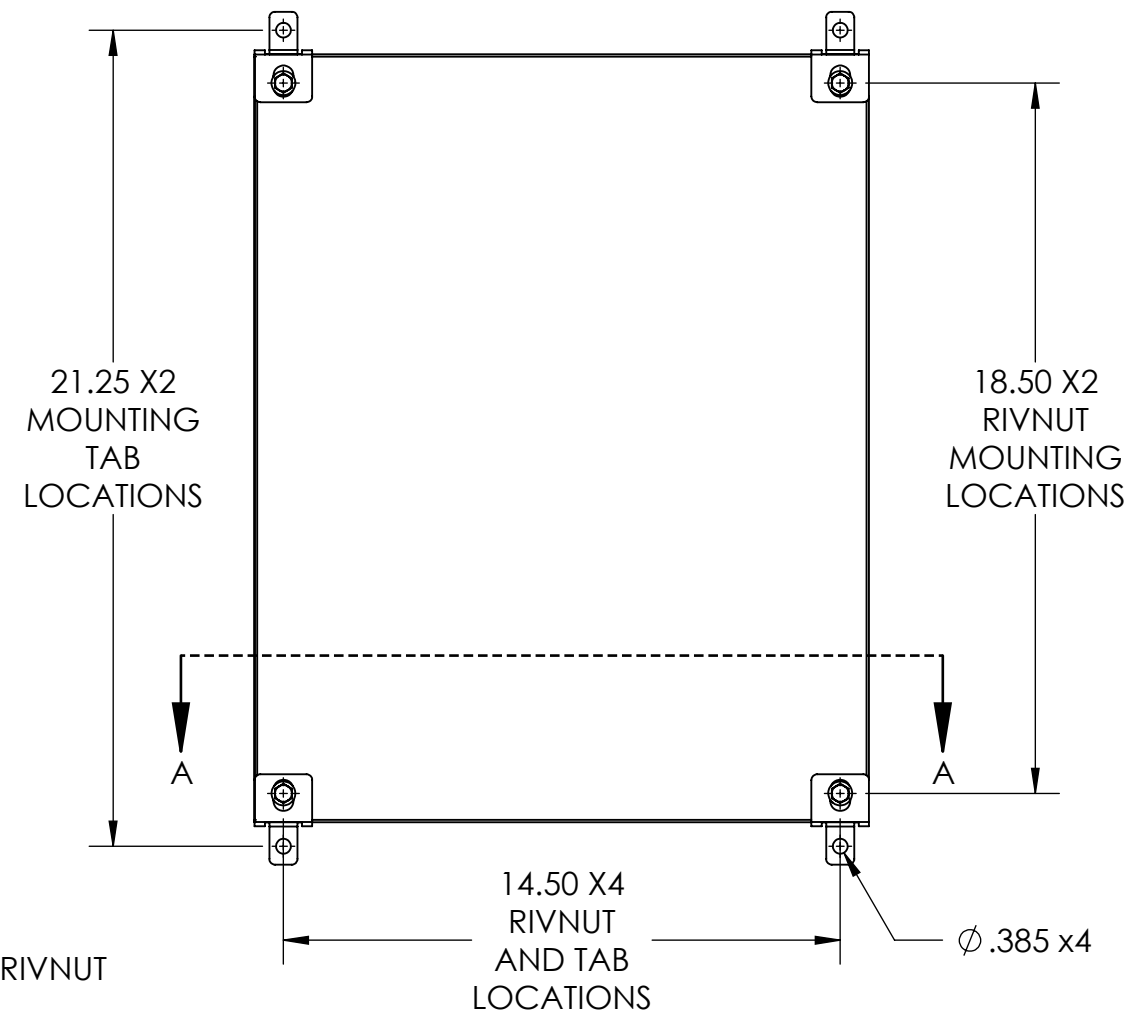

DETAIL B
SCALE 3 : 4

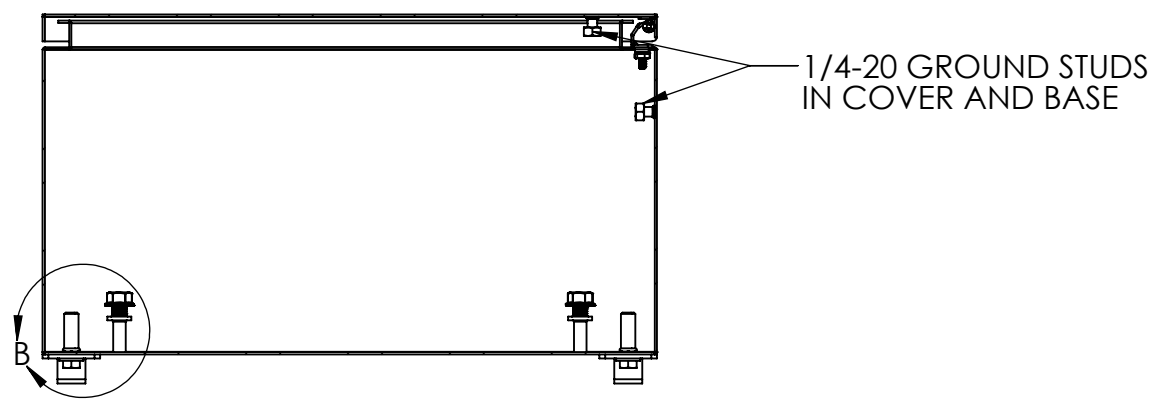

SECTION A-A

A

INTEGRA ENCLOSURES
 A DIVISION OF MUM INDUSTRIES
 8989 TYLER BLVD. MENTOR, OH
 ENCLOSURES (440)269-8155 FAX (440)269-8166

UNLESS OTHERWISE SPECIFIED:
 DIMENSIONS ARE IN INCHES [MM]
 AND ARE NOMINAL ONLY

PROPRIETARY AND CONFIDENTIAL
 THE INFORMATION CONTAINED IN THIS
 DRAWING IS THE SOLE PROPERTY OF
 MUM INDUSTRIES INC. ANY
 REPRODUCTION IN PART OR AS A WHOLE
 WITHOUT THE WRITTEN PERMISSION OF
 MUM INDUSTRIES INC. IS PROHIBITED.

DWG. NO.		
WEB-W201608-4PQ-BT		
SIZE	DESCRIPTION:	REV
B	WALL-20X16X08-304- PHN-QTL	G
DRAWN BY:	CV	05.05.2021
SCALE: 1:5	WEIGHT:	SHEET 2 OF 2

4

3

2

1

A

A