

4

3

2

1

B

B

A

A

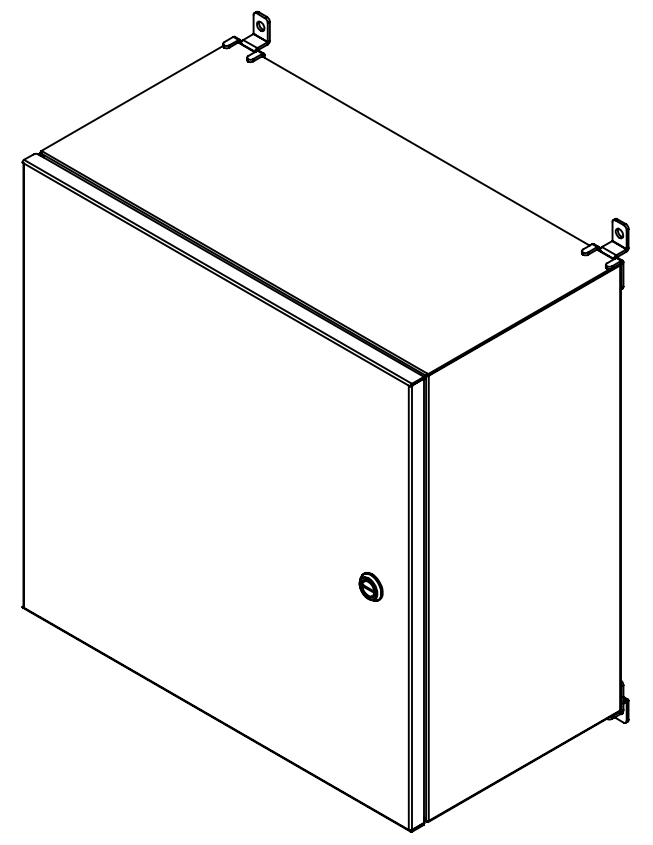
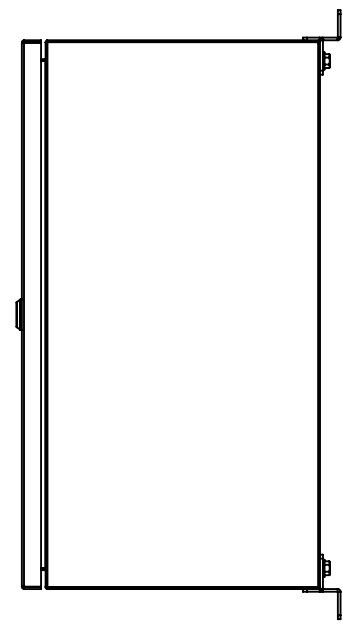
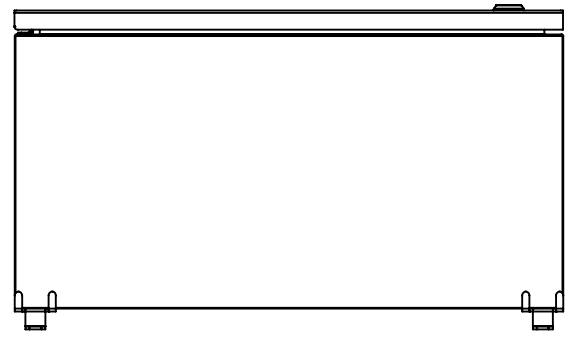
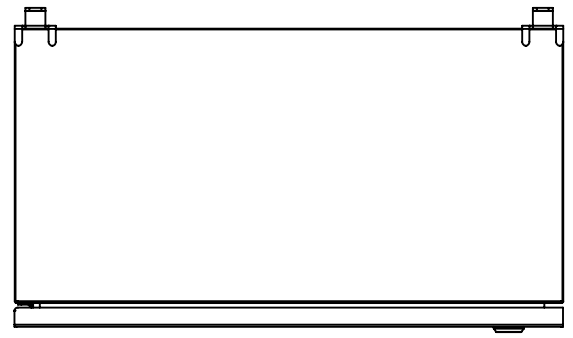
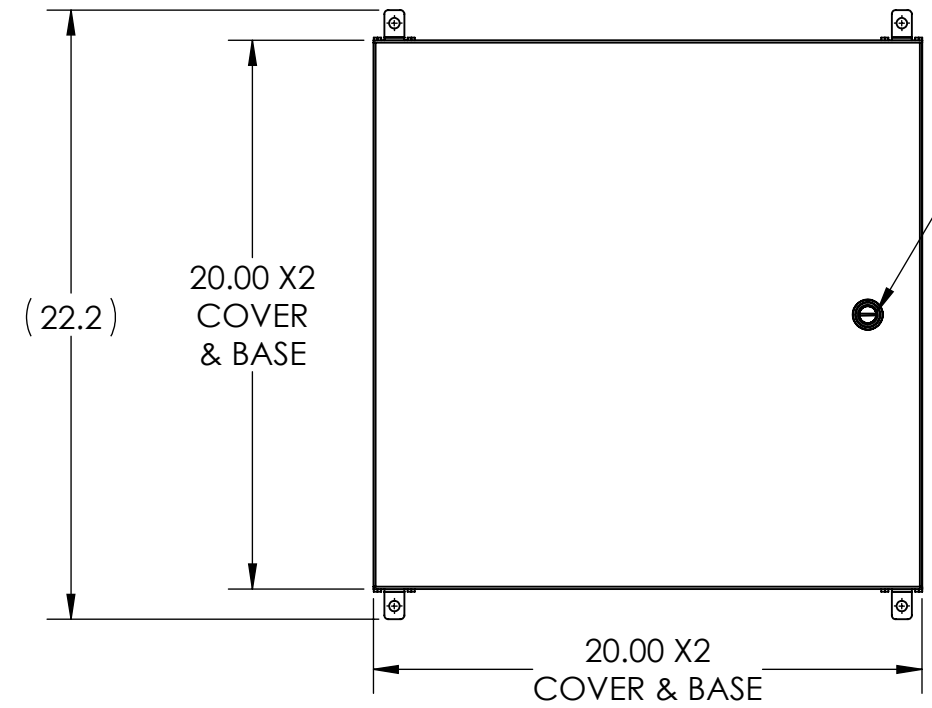
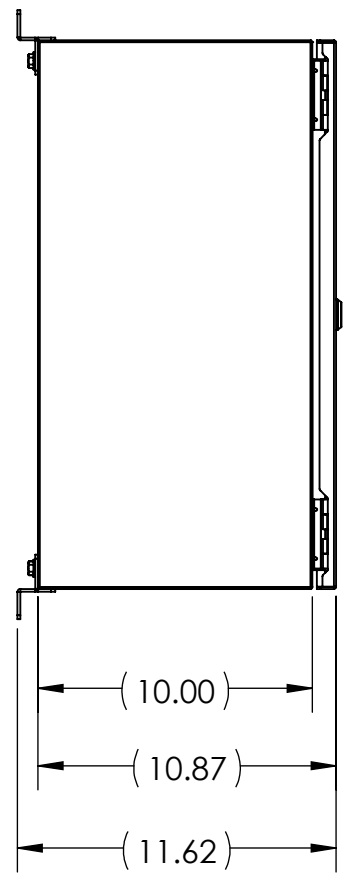

- NOTES:
 1. BASE MATERIAL: 16 Ga. (.060") 304 SS
 2. COVER MATERIAL: 14 Ga. (.075") 304 SS

INTEGRA ENCLOSURES
 A DIVISION OF MUM INDUSTRIES
 8989 TYLER BLVD. MENTOR, OH
 (440)269-8155 FAX (440)269-8166

UNLESS OTHERWISE SPECIFIED: DIMENSIONS ARE IN INCHES [MM] AND ARE NOMINAL ONLY			DWG. NO. W202010-4PQ-BT		
PROPRIETARY AND CONFIDENTIAL THE INFORMATION CONTAINED IN THIS DRAWING IS THE SOLE PROPERTY OF MUM INDUSTRIES INC. ANY REPRODUCTION IN PART OR AS A WHOLE WITHOUT THE WRITTEN PERMISSION OF MUM INDUSTRIES INC. IS PROHIBITED.			SIZE B	DESCRIPTION: WALL-20X20X10-304- PHN-QTL	REV E
DRAWN BY:	DLA	04.12.2021	SCALE: 1:7	WEIGHT:	SHEET 1 OF 2

4

3

2

1

4

3

2

1

B

B

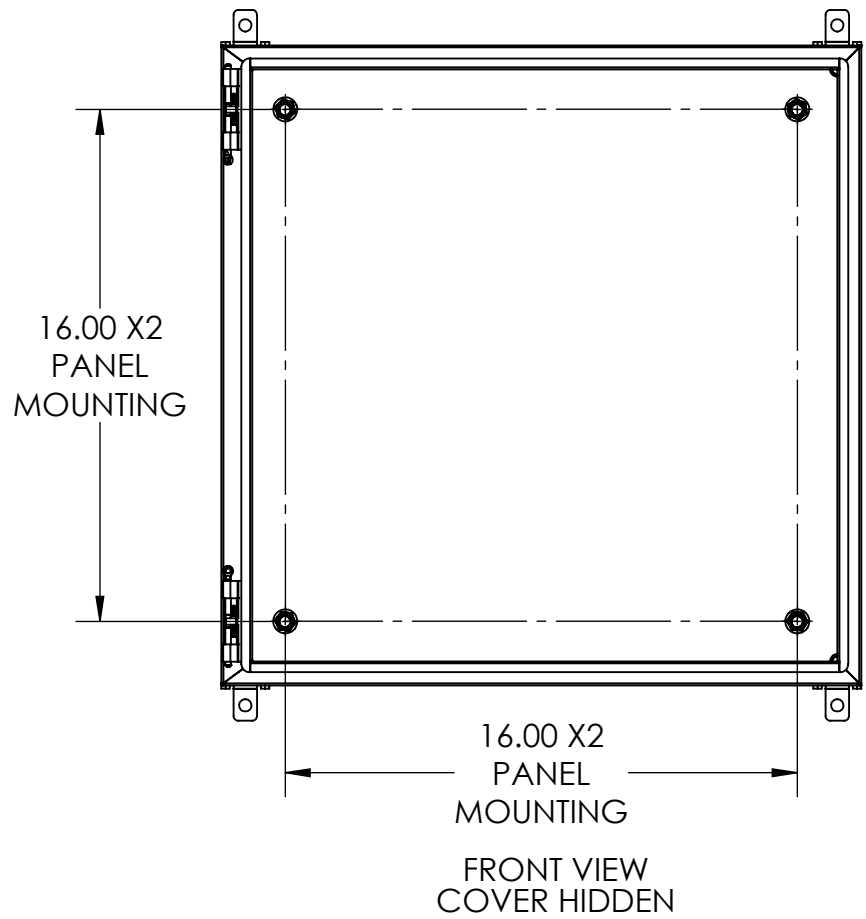
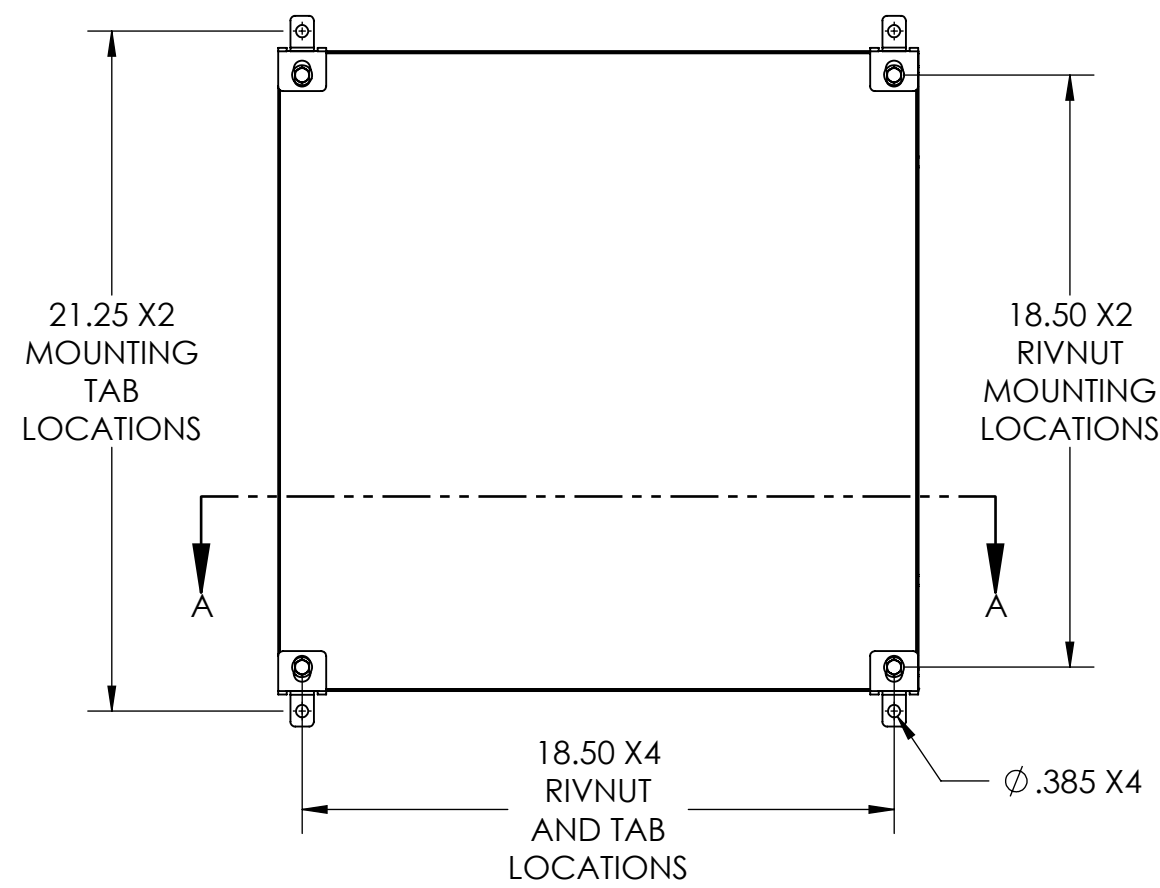

A

A

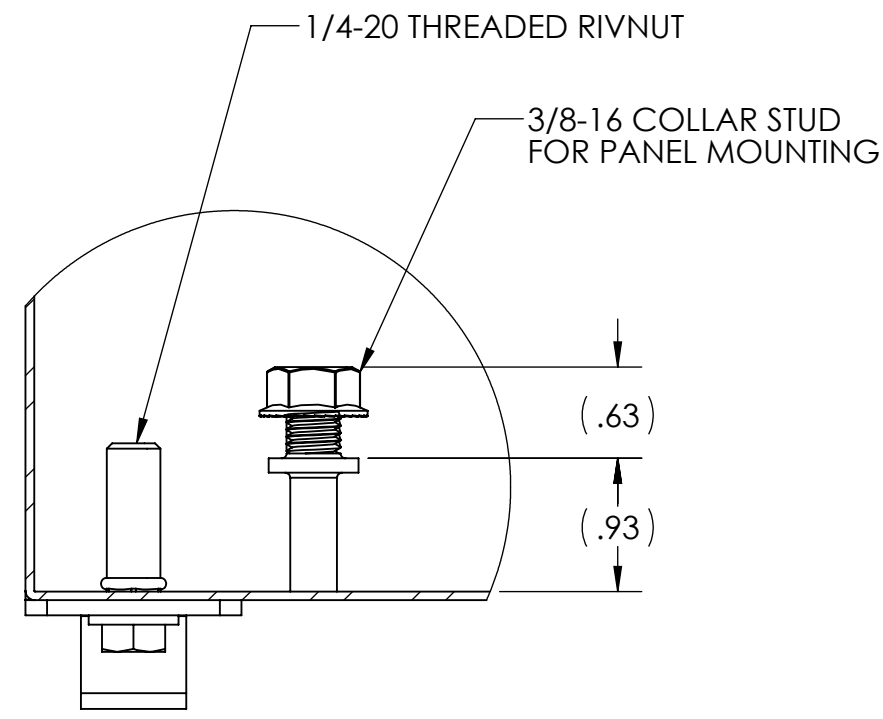

DETAIL B
SCALE 3 : 4

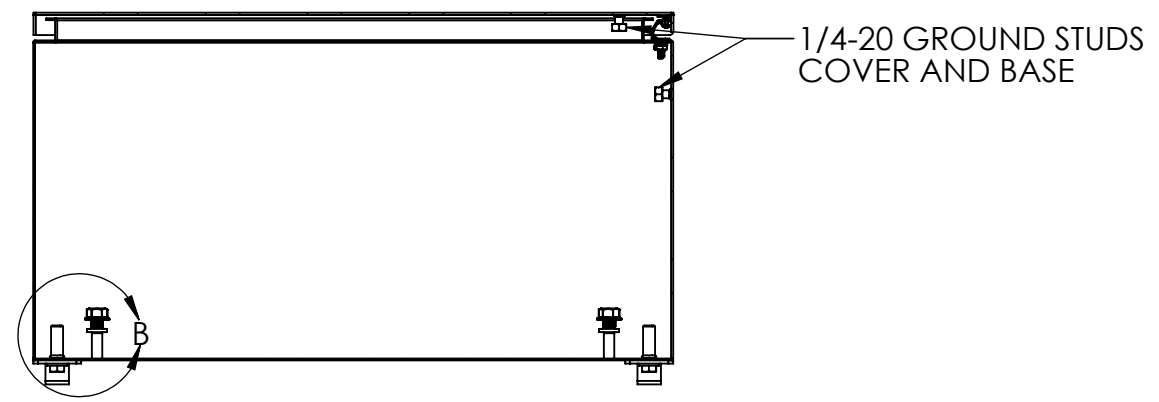

SECTION A-A

INTEGRA ENCLOSURES
 A DIVISION OF MUM INDUSTRIES
 8989 TYLER BLVD. MENTOR, OH
 (440)269-8155 FAX (440)269-8166

UNLESS OTHERWISE SPECIFIED: DIMENSIONS ARE IN INCHES [MM] AND ARE NOMINAL ONLY		DWG. NO. W202010-4PQ-BT	
PROPRIETARY AND CONFIDENTIAL THE INFORMATION CONTAINED IN THIS DRAWING IS THE SOLE PROPERTY OF MUM INDUSTRIES INC. ANY REPRODUCTION IN PART OR AS A WHOLE WITHOUT THE WRITTEN PERMISSION OF MUM INDUSTRIES INC. IS PROHIBITED.		SIZE B	DESCRIPTION: WALL-20X20X10-304- PHN-QTL
REV E	SCALE: 1:6	WEIGHT:	SHEET 2 OF 2

4

3

2

1