

4

3

2

1

B

B

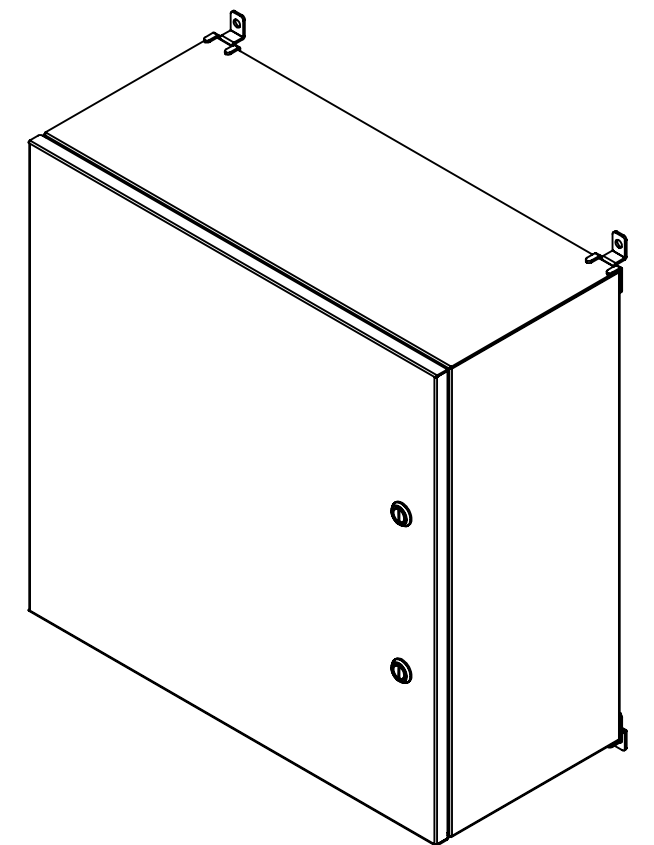
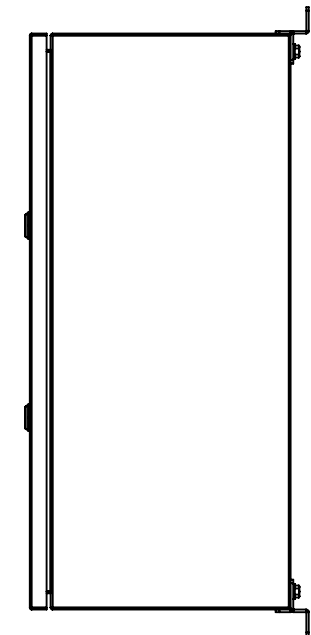
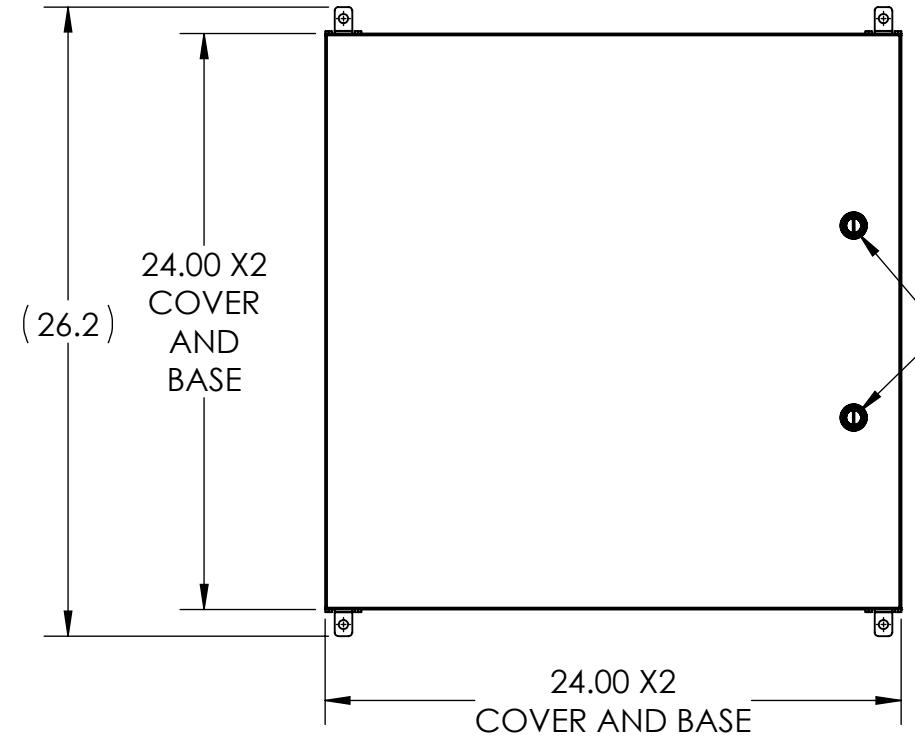
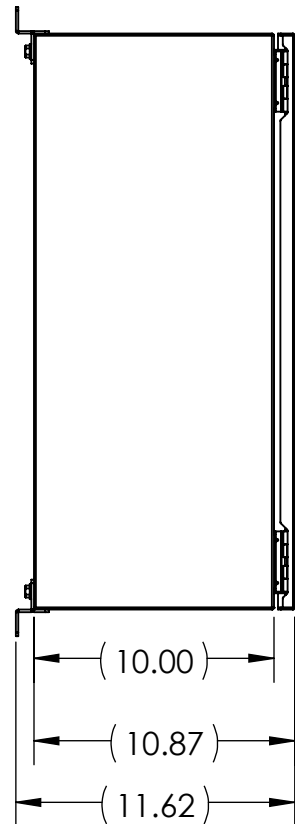

A

A

4

3

2

1

- NOTE:  
 1. BASE MATERIAL: 14 Ga. (.075") 304 SS  
 2. COVER MATERIAL: 14 Ga. (.075") 304 SS

**INTEGRA ENCLOSURES**  
 A DIVISION OF MUM INDUSTRIES  
 8989 TYLER BLVD. MENTOR, OH  
 (440)269-8155 FAX (440)269-8166

UNLESS OTHERWISE SPECIFIED: DIMENSIONS ARE IN INCHES [MM] AND ARE NOMINAL ONLY			DWG. NO. <b>W242410-4PQ-BT</b>		
<b>PROPRIETARY AND CONFIDENTIAL</b> THE INFORMATION CONTAINED IN THIS DRAWING IS THE SOLE PROPERTY OF MUM INDUSTRIES INC. ANY REPRODUCTION IN PART OR AS A WHOLE WITHOUT THE WRITTEN PERMISSION OF MUM INDUSTRIES INC. IS PROHIBITED.			SIZE <b>B</b>	DESCRIPTION: WALL-24X24X10-304-PHN-QTL	REV <b>G</b>
DRAWN BY:	ZNT	05.18.2021	SCALE: 1:8	WEIGHT:	SHEET 1 OF 2

4

3

2

1

B

B

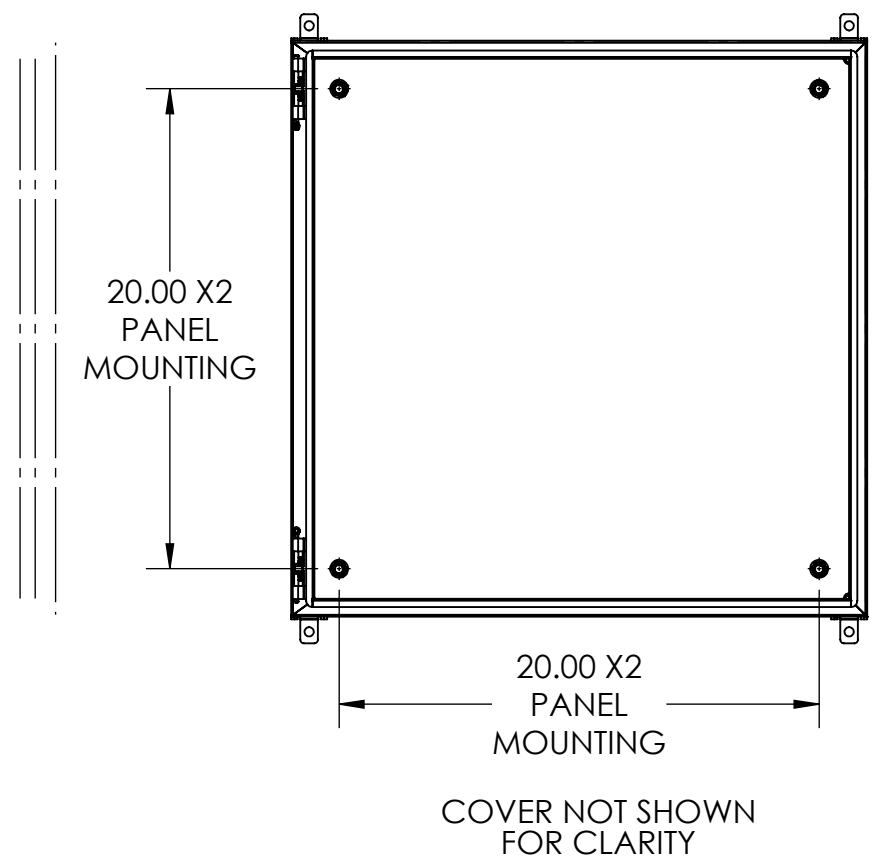
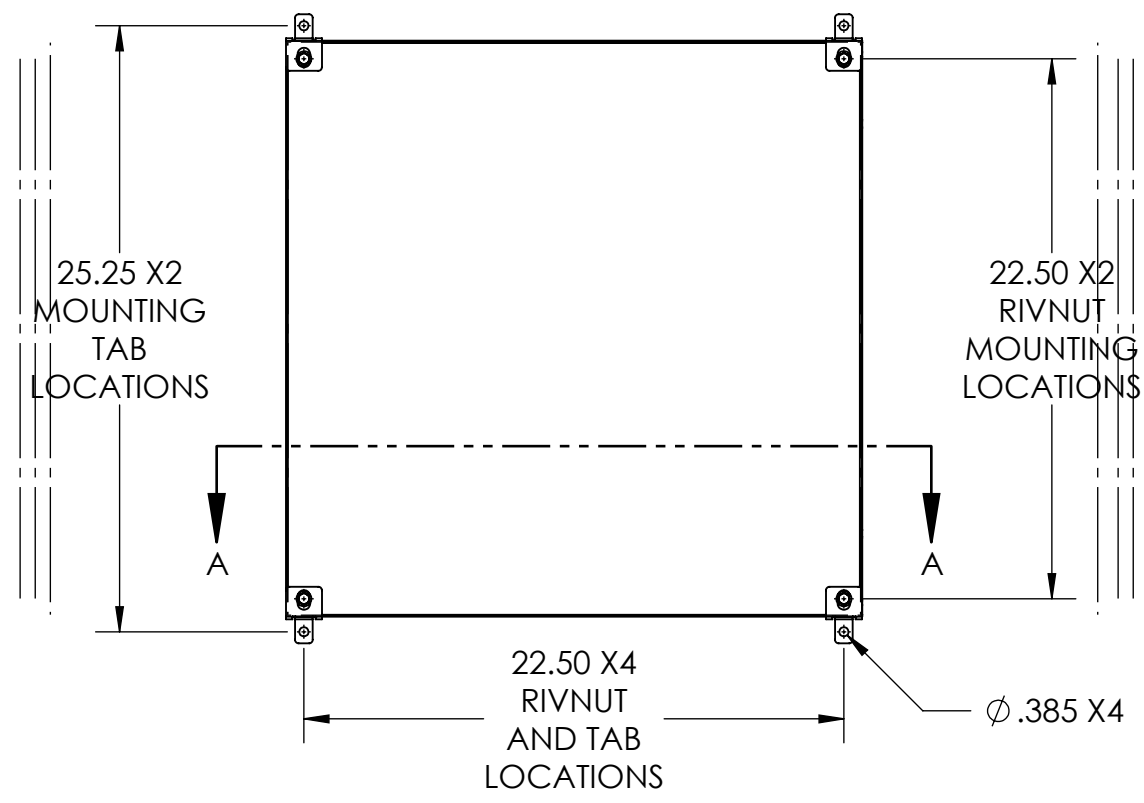

A

A

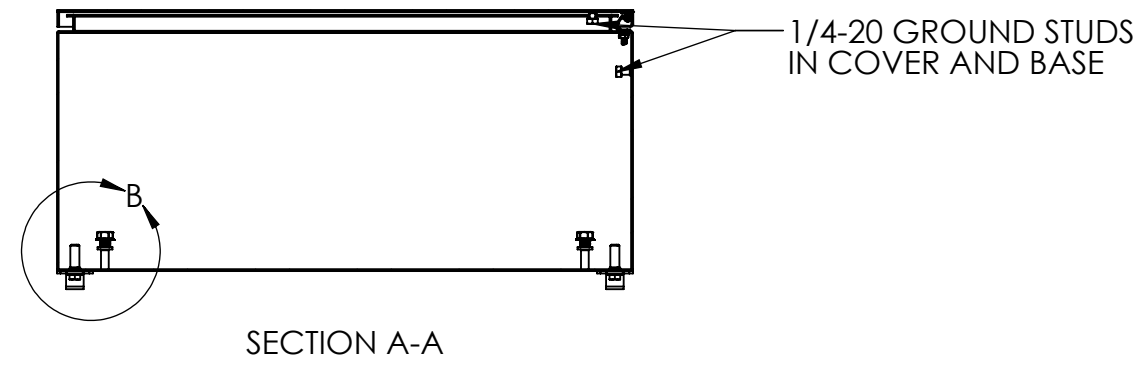
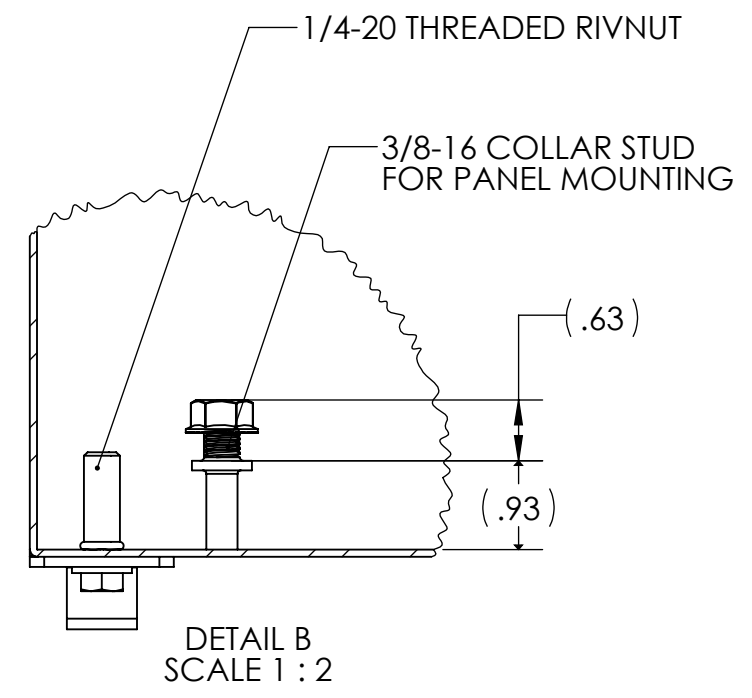

UNLESS OTHERWISE SPECIFIED:  
DIMENSIONS ARE IN INCHES [MM]  
AND ARE NOMINAL ONLY

**PROPRIETARY AND CONFIDENTIAL**  
THE INFORMATION CONTAINED IN THIS  
DRAWING IS THE SOLE PROPERTY OF  
MUM INDUSTRIES INC. ANY  
REPRODUCTION IN PART OR AS A WHOLE  
WITHOUT THE WRITTEN PERMISSION OF  
MUM INDUSTRIES INC. IS PROHIBITED.

DRAWN BY: ZNT 05.18.2021

**INTEGRA ENCLOSURES**  
A DIVISION OF MUM INDUSTRIES  
8989 TYLER BLVD. MENTOR, OH  
(440)269-8155 FAX (440)269-8166

DWG. NO. <b>W242410-4PQ-BT</b>		
SIZE <b>B</b>	DESCRIPTION: WALL-24X24X10-304- PHN-QTL	REV <b>G</b>
SCALE: 1:8	WEIGHT:	SHEET 2 OF 2

4

3

2

1